

Intelligent Drip Irrigation System Using Linear Programming and Interpolation Methodology

Mr. Dnyaneshwar Natha Wavhal ^{a*}, Prof. Manish Giri ^b

^aMIT Academy of Engineering Alandi(D), University Of Pune, Pune-412105, India

^bMIT Academy of Engineering Alandi(D), University Of Pune, Pune-412105, India

^aEmail: dnyaneshwar.wavhal@gmail.com

^bEmail: mbgiri@comp.maepune.ac.in

Abstract

In this paper, the Design of Intelligent Drip Irrigation system for the Automation of Drip irrigation is presented. Generally the Drip irrigation was named in Israel in 1959. Drip Irrigation is today's need because water is nature's gift to the mankind and it is not unlimited and free forever. World's water resources are fastly vanishing. The one and only one solution to this problem is Intelligent Drip Irrigation system. In the conventional drip irrigation system, the farmer has to keep watch on irrigation timetable, which is different for different crops. In Intelligent Drip Irrigation using Linear Programming irrigation will take place only when there will be intense requirement of water. Irrigation system uses valves to turn irrigation ON and OFF. These valves may be easily automated by using controllers and solenoids. The developed irrigation method removes the need for workmanship for flooding irrigation as well as drip irrigation along with that it allows the farmer to apply the right amount of water at the right time, regardless of the availability of the labour to turn valves or motor ON & OFF. In this presented Intelligent Irrigation system I have used linear programming concept and Interpolation Method. Linear Programming helps us to distribute available water to the number of crops in order to get maximum profit with minimum cost. Also linear Programming helps us to do proper management of available water. Interpolation Method is used to map the physical parameters readings in the farm where taking manual readings is not possible. Finally both the methodology helps us to increase productivity of the crops and ultimately profit.

Keywords: ATmega-32 Microcontroller; Drip Irrigation; Interpolation; Light Sensor; Linear Programming; Soil Moisture Sensor; Temperature Sensor; Wireless Sensor Nodes; Wireless Sensor Network.

* Mr.Dnyaneshwar Natha Wavhal.; Mob.: +91-9860743411;
E-mail address: dnyaneshwar.wavhal@gmail.com.

1. Introduction

It has been ten years since drip irrigation was introduced in California to be used on commercial agricultural crops. The initial work was started in an avocado orchard in San Diego County, and from this small five-acre experimental orchard the acreage has increased tremendously. Many crops are under test with drip irrigation. Equipment used in drip irrigation systems is very important.

There are many pieces of equipment required. They include plastic hose or pipe, spaghetti hose, emitters, pressure regulators, pressure gauges, valves, fertilizer tanks, filters — both sand and screen, time clocks, Tensiometer, evaporative pans, meters, and fertilizer injectors. One of the most important items in the hardware for drip irrigation systems is the filter. An automated management of green house brings about precise control needed to provide the most proper condition of plant growth. The five most important parameters to consider when creating drip irrigation are humidity, temperature, ground water, carbon dioxide, light intensity [6].

In this paper an advance microcontroller ATmega-32 which is 32-bit features of 32kb internal memory, 32 bit timers and 10 bit built in ADC analog to digital converter is used. A timer for the automation of drip irrigation is set, which works accordingly to the sensors and combining all this features the flow of water in fields will be automatically controlled rather than manually. It also contains the temperature and moisture sensor.

Sensors are installed in the root zone at the undisturbed soil. The soil moisture sensor is a sensor connected to an irrigation system controller that measures soil moisture content in the active root zone. Soil moisture sensor can reduce irrigation application by 50%. Water saving have been measured between 5% to 88% over typical timer -base irrigation system. Sensors are placed at least 5 ft from the downspouts for avoiding the high moisture areas. Tensiometer can be used as the moisture sensor to detect moisture contents of soil.

2. Objectives

- Resource Optimization in Drip Irrigation System
- To Provide the Decision Support for Automated Drip Irrigation system.
- Handle the system manually as well as automatically.
- Detect water level in order to do proper distribution.
- To save water, energy and man power in the agriculture sector.
- To Design such a system that will be efficient and effort reducing of the farmer

3. Proposed System

In Existing Drip Irrigation system it is not possible to operate it on Multiple decisions, it just operated only on single soil conditions like soil moisture, ph_value, temperature and light. It

operates on only one condition at a time. It is somewhat similar to the existing automated drip irrigation system, but along with that my aim is to make my proposed system to be more intelligent that's why I am going to use linear programming in my proposed system. In Conventional Automated Drip Irrigation system it is not possible to operate it on decisions, it just operated only on single soil conditions like soil moisture, ph_value, temperature and light. It operates on only one condition at a time like if we using soil moisture sensor to control automated drip irrigation then whenever soil moisture level is get decrease then and then only it direct the Valve Unit to change its position from OFF to ON, and if soil moisture level is go to the proper pre-setted level at that time system is get OFF automatically. Here it is not going to check availability of water and exact requirement of water to the crop. But my system is going to check that and on that basis it is get operated. For that purpose I'm using linear programming approach in order to do proper use of available water to all the avail- able crops in the field or farm where our system is get implemented to get maximum profit and also with the help of linear programming we easily identify available water and required water for the crops.

4. System Architecture and its Working

The aim is to design Intelligent Irrigation System Using Linear Programming. This system must be able to control the Valve timings of drips automatically based on pre-programmed timings. The time intervals for all the Valves can be fed into PC for an entire week or month. Regional language based GUI must be developed so that novice users must be able to feed in the timings or program the hardware. An ADC connected to micro controller must gather the humidity values for soil at various points. These values must be visualized in software using 3D plots to assist the user in deciding valve timings.

In this system Computer Can read the ADC values also receives sensor data and on the basis of ADC values and Sensor data we can apply linear programming in order to generate optimum watering plan i.e. Minimum Water → Maximum Productivity → Maximum Profit . on the basis of values that we have read from ADC and Sensor we can easily apply linear programming in order to generate optimum watering plan through which we can generate drip control commands and later on we transmit that drip commands to the Hardware Device. Hardware device is totally operated on wireless network. i.e. Computer can communicate with hardware device through WSN.

The important parameters to be measured for automation of irrigation system are soil moisture, temperature and light. The entire field is first divided in to small sections such that each section should contain one moisture sensor, a temperature sensor and one light sensor. LM35 can be used as a temperature sensor while Tensiometer can be used as the moisture sensor to detect moisture contents of soil. These sensors are buried in the ground at required depth. Once the soil has reached desired moisture level the sensors send a signal to the micro controller to turn off the relays, which control the valves.

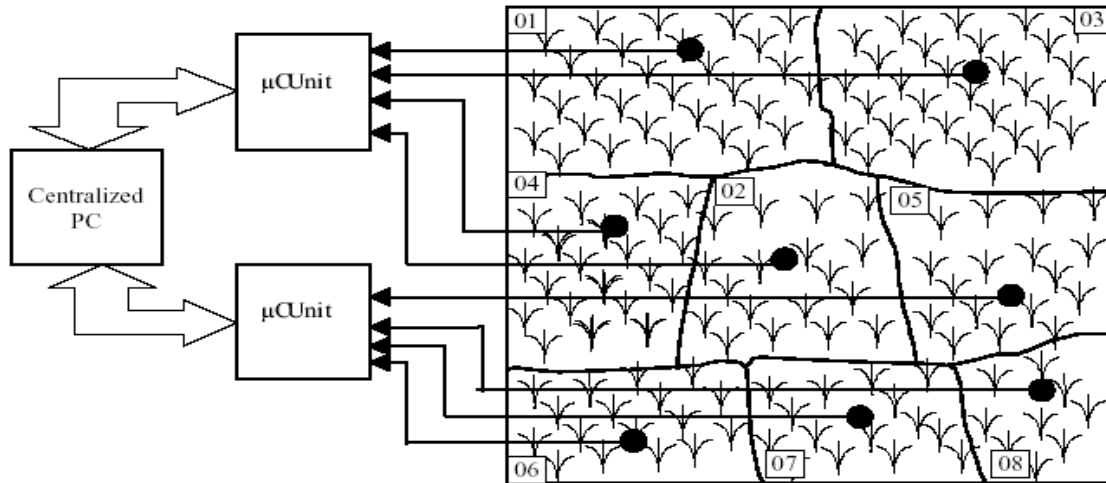

Fig.3. Application to the Farm

The automated control system consists of moisture sensors, temperature sensors, Signal conditioning circuit, Digital to analog converter, Relay driver, solenoid control valves, etc. The unit is expressed in Figure above. The signal send by the sensor is boosted up to the required level by corresponding amplifier stages. Then the amplified signal is fed to A/D converters of desired resolution to obtain digital form of sensed input for microcontroller use. While applying the automation on large fields more than one such microcontroller units can be interfaced to the Centralized Computer. The microcontroller unit has in-built timer in it, which operates parallel to sensor system. In case of sensor failure the timer turns off the valves after a threshold level of time, which may prevent the further disaster. The microcontroller unit may warn the pump failure or insufficient amount water input with the help of flow meter.

5. Interpolation Method

To map the physical parameter readings for areas in farm where taking manual readings is not possible, that means it is difficult to take manual readings from that area.

EX. If we have a reading at 1 point and then directly at 2nd point 25 meters away. Then we shall interpolate the values for points at every meter between the two measured points.

Interpolation:-Interpolation is a method of constructing new data points within the range of a discrete set of known data points.

Extrapolation: - The term extrapolation is used if we want to find data points outside the range of known data points.

6. Linear Programming

Linear programming (LP or linear optimization) is a mathematical method for determining a way to achieve the best outcome (such as maximum profit or lowest cost) in a given mathematical model for some list of requirements represented as linear relationships. Linear programming is a specific case of mathematical programming (mathematical optimization).

- To evaluate control parameters like how much total water we have and what quantities of different crops must be used to give optimum throughput.
- EX. How to divide drip water timings in order to attain best possible throughput.

7. Wireless Sensor Network(WSN).

A wireless sensor network (WSN) consists of spatially distributed autonomous sensors to monitor physical or environmental conditions, such as temperature, sound, vibration, pressure, motion or pollutants and to cooperatively pass their data through the network to a main location. The more modern networks are bi-directional, also enabling control of sensor activity. The development of wireless sensor networks was motivated by military applications such as battlefield surveillance, today such networks are used in many industrial and consumer applications, such as industrial process monitoring and control, machine health monitoring, and so on. Wireless sensor networks (WSN) have recently been proposed for a large range of applications in home and industrial automation. It consists of many tiny nodes, which have several sensors and a radio interface that depends on the IEEE 802.15.4 standard that supports large number of embedded devices in one network. WSN can be used for many applications such as environment monitoring, medical applications, robotic systems and home and industrial automation.

8. Experimental Setup

The soil moisture sensor which is used in this application has been located 20 cm of depth from ground and 50 cm far away from the crop.

9. Algorithms Involved In Intelligent Drip Irrigation System

In this system there are three Main Algorithms

- 1) Mater Side Algorithm
- 2) Node Side Algorithm
- 3) Remote Side Algorithm

The algorithms are as follows

9.1. Master Side Algorithm

- 1) Start
- 2) Initialize $i=1$
- 3) Select Xbee Node i
- 4) Send Address
- 5) Send ADC Read Command
- 6) Read Sensor Value at Node i
- 7) $i=i+1$
- 8) Repeat steps 3 to 7 for all Nodes.
- 9) Evaluate sensor values
- 10) Apply Linear Programming
- 11) Generate control data
- 12) Send Xbee Address
- 13) Send H/W relay/pump control command
- 14) Submit log to Remote Server.
- 15) Goto step 2

9.2. Node Side Algorithm

- 1) Initialize Micro-Controller
- 2) Read Self Address
- 3) Wait for XBee Command
- 4) Read Xbee Command

5) If ADC Command, read ADC value send back to Xbee

Else if DEVICE Command Control Drips.

End

6) Goto step 3

9.3. Remote Side Algorithm

1) Start

2) Initialize Server (Tomcat Apache)

3) Wait for Client request

4) Read client request

5) Read latest submitted drip data

6) Send data to client as response

7) Goto step 3

These are the main algorithms on which my system runs.

10. Results and Discussion

The proposed work as follows.

Here in this system I have control system by using soil moisture sensor, temperature sensor and light sensor. That means drip it will be get ON and OFF on the soil moistures sensors reading, if soil moisture is below pre-setted threshold value in that case Water pump it will get ON and also respective Drip or Valve is get ON and release particular amount of water to the soil. Once soil reaches to its presetted moisture level then the Valve as well as Water Pump will OF automatically. Apart from that have combine temperature sensor and light sensor. If temperature of the air t will get increases and it exceed the pre-setted limit of threshold values at that time automatically Fans will be get ON, it temperature remains below the threshold values at that time Fan Remains OFF. Also if light intensity is below the threshold values at that time bulb will ON automatically and if it equal or above the threshold value at that time bulb remains OFF.

When this system is get used in control environment then we get all the results from this system. But when this system is get used in uncontrolled environment then it works as usual but by using linear

programming though it will be get used in uncontrolled environment it water distribution will done properly. I am going to calculate volumetric water content of the soil by using this formula.

$$VWC(m3/m3) = 1.17 * 10^{-9} * ADC3 - 3.95 * 10^{-6} * ADC2 + 4.90 * 10^{-3} * ADC - 1.92$$

Thereafter have recorded temperature and light readings on ordinary day. All the recorded readings are as follows.

Table.1. Live Readings (Recorded Reading on Ordinary Day)

Time	Temperature		Soil Moisture		Light	
	Node 1	Node 2	Node 1	Node 2	Node 1	Node 2
09:30	25.1	24.3	64.1	65.4	114.8	115.1
10:00	25.8	24.9	64.3	64	117.8	118.1
10:30	33.5	32.9	63.5	62.7	120.5	120.4
11:30	31.6	30.9	62.9	62.8	123.3	123.7
12:30	28.3	28.1	61.3	61.6	128.0	127.5
01:00	32.3	32.1	60.5	60.8	128.0	128.0
01:30	34.8	34.6	59.2	59.1	128.0	128.0
02:30	30.9	30.5	58.6	58.3	128.0	128.0
03:30	32.6	32.1	57.2	57.9	127.3	127.6
04:00	31.4	31.0	56.6	56.2	126.1	126.3
04:30	29.2	30.0	55.1	55.5	115.3	114.7
05:54	28.5	28.1	54.3	54.2	110.4	111.1

Table.2. Statistical Analysis of Result Values

Time	Drip Irrigation Without Using L.P.		Drip Irrigation Using L.P	
	Water(Liters)	Power(Watts)	Water(Liters)	Power(Watts)
09:00- 10:00	2000	4000	2000	4000
10:30-11:30	2000	4000	1000	2000
12:00-12:30	1000	2000	700	1400
12:45-01:50	2400	4800	1300	2600
02:00-03:00	2000	4000	1000	2000
03:10-04:10	2000	4000	800	1600
04:15-05:15	2000	4000	600	1200
05:20-06:20	2000	4000	500	1000
Total	15400 Liters	30800Watts	7900 Lietrs	9000 Watts
	15400-7900=7500 Liters		30800-15800=15000Watts	
	Water Saved=48.7%		Power Saved=48.7%	

Table.3. Recommended maximum volumetric water content for various crops

Crop	VWC	Crop	VWC
Onion	50-70	Corn	60-80
Tomato	60-150	Potato	30-50

Thus by using this system one can save water and power/energy upto 50%. And have successfully developed wireless sensor network based effective automated intelligent drip irrigation system. Which will provide regularly updated soil moisture and ground water data at different spots and different depths in the field.

11. Conclusion

The Intelligent Drip Irrigation using linear programming provides to be a real time feedback control system which monitors and controls all the activities of drip irrigation system efficiently, and by using this system one can save up to 50 % of water and power. The present system is model to modernize the agriculture industries at the mass scale with optimum expenditure. This is the first of its kind in using linear programming for drip irrigation systems. Using this system, one can save manpower, water, energy/power to improve production and ultimately profit.

12. Future Enhancement

For future enhancement it is possible to registered farmer to download drip control timings from agricultural universities website and control own drip irrigation system according to university.

Also it is possible to control this internet based drip irrigation system by using android supported mobile cell phones.

References

- [1] Dnyaneshwar Wavhal and Manish giri “Automated intelligent wireless drip irrigation using linear programming” International Journal of Advanced Research in Computer Engineering & Technology (IJARCET) Volume 2, Issue 1, January 2013, ISSN: 2278 – 1323, pp.1-5
- [2] Dnyaneshwar Wavhal and Manish Giri “Automated Drip Irrigation Improvements Using Wireless Application”, International Journal of Advance Research, IJOAR .org, Volume 1, Issue 3, March 2013, Online: ISSN 2320-9194, pp.65-73
- [3] Dnyaneshwar Wavhal, Manish Giri and Sneha Ghumatkar “Decision Support Support System for Drip Irrigation ”, International Journal of Emerging Technology and Advanced Engineering, Website: www.ijetae.com (ISSN 2250-2459, ISO 9001:2008 Certified Journal, Volume 4, Issue 4, April 2014, pp.463-470
- [4] Mahir Dursun and Semih Ozden ”A wireless application of drip irrigation automation supported by soil moisture sesors”,Scientific Research and Essays Vol. 6(7), pp. 1573-1582, 4

- April, 2011 .Available on- line at <http://www.academicjournals.org/SRE> ISSN 1992-2248 I2011 Academic Journals.
- [5] Awati J.S., and Patil V.S. ETC department, RIT, Sakharale, Sangli, MS, India.SETI, Panhala, Kolha pur, MS, India. "Automatic Irrigation Control by using wireless sensor networks", Journal of Exclusive Management Science - June 2012-Vol 1 Issue 6 – ISSN 2277 - 5684.
- [6] Shiv Sutar, Swapnita-Jayesh, Komal-Priyanka MIT- COE, Pune, Maharashtra. "Irrigation and Fertilizer control for Precision Agriculture using WSN: Energy Efficient Approach", International Journal of Advances in Computing and Information Researches, ISSN: 2277-4068, Volume 1 No.1, January 2012
- [7] Anurag D, Siuli Roy and Somprakash Bandyopad- hyay, Indian Institute of Management Calcutta, Kolkata, India "Agro-Sense Precision Agriculture using sensor based wireless mesh networks".
- [8] J.Panchard, P.R.S.Rao, M.S. Sheshshayee, P. Pa- padimitratos and J.-P. Hubaux , "Wireless Sensor Networking for Rain-fed Farming Decision Support".
- [9] Jyothipriya.a.n. and T.P.Saravanabava "Cell Phone Based Wireless Network Controlled Embedded System For Drip Irrigation", methods enriching power & energy developments (MEPED'13) April 12th, 2013, ISSN:-2230-7850
- [10] K.Prathyusha1, M. Chaitanya Suman2"Design Of Embedded Systems For The Automation Of Drip Irrigation", International Journal of Application or Innovation in Engineering & Management (IJAIEM)Web Site: www.ijaiem.org Email: editor@ijaiem.org, editorijaiem@gmail.com, Volume 1, Issue 2, October 2012, ISSN 2319 – 4847
- [11]"Irrigating Basics" published in American nurseryman, December 1, 2007
- [12]Ayman Sleman and Reinhard Moeller, Automation and Process Control Engineering, "Integration of Wireless Sensor Network Services into other Home and Industrial networks using Device Profile for Web Services (DPWS)".
- [13]P.Raghuram, and Veeramuthu Venkatesh, School Of Computing, SASTRA University, Thanjavur, Tamil Nadu, India, "Enhancing Mine Safety with Wire- less Sensor Networks using Zigbee Technology". Journal of Theoretical and Applied Information Tech- nology 31st March 2012. Vol. 37 No.2,ISSN:1992 -8645,www.jatit.org, E-ISSN: 1817-3195
- [14]Meijering, Erik (2002), "A chronology of interpolation: from ancient astronomy to modern signal and image processing", Proceedings of the IEEE 90 (3):319-342, doi:10.1109/5.993400.
- [15]R.E. Crochiere and L.R. Rabiner. (1983). "Multirate Digital Signal Processing". Englewood Cliffs, NJ: Prentice-Hall. ([http:// www. amazon.com/ Multirate-Digital-Signal-Processing- Crochiere/dp/013605162](http://www.amazon.com/Multirate-Digital-Signal-Processing-Crochiere/dp/013605162)"6).
- [16]Murty, Katta G. (1983). Linear programming. New York: John Wiley Sons, Inc.. pp. xix+482.ISBN 0-471-09725-X. MR720547. (Comprehensive reference to classical approaches).
- [17]M. Padberg, Linear Optimization and Extensions, Second Edition, Springer-Verlag, 1999.